

### Hoist Type

Load capacity:	0.5 t	Lifting speed:	5/1.3 m/min
Duty mode (FEM/ISO):	1Am / M4	Travelling speed:	20/5 m/min
Hook path (Hmax):	6 m		
Chain Falls:	1/1		

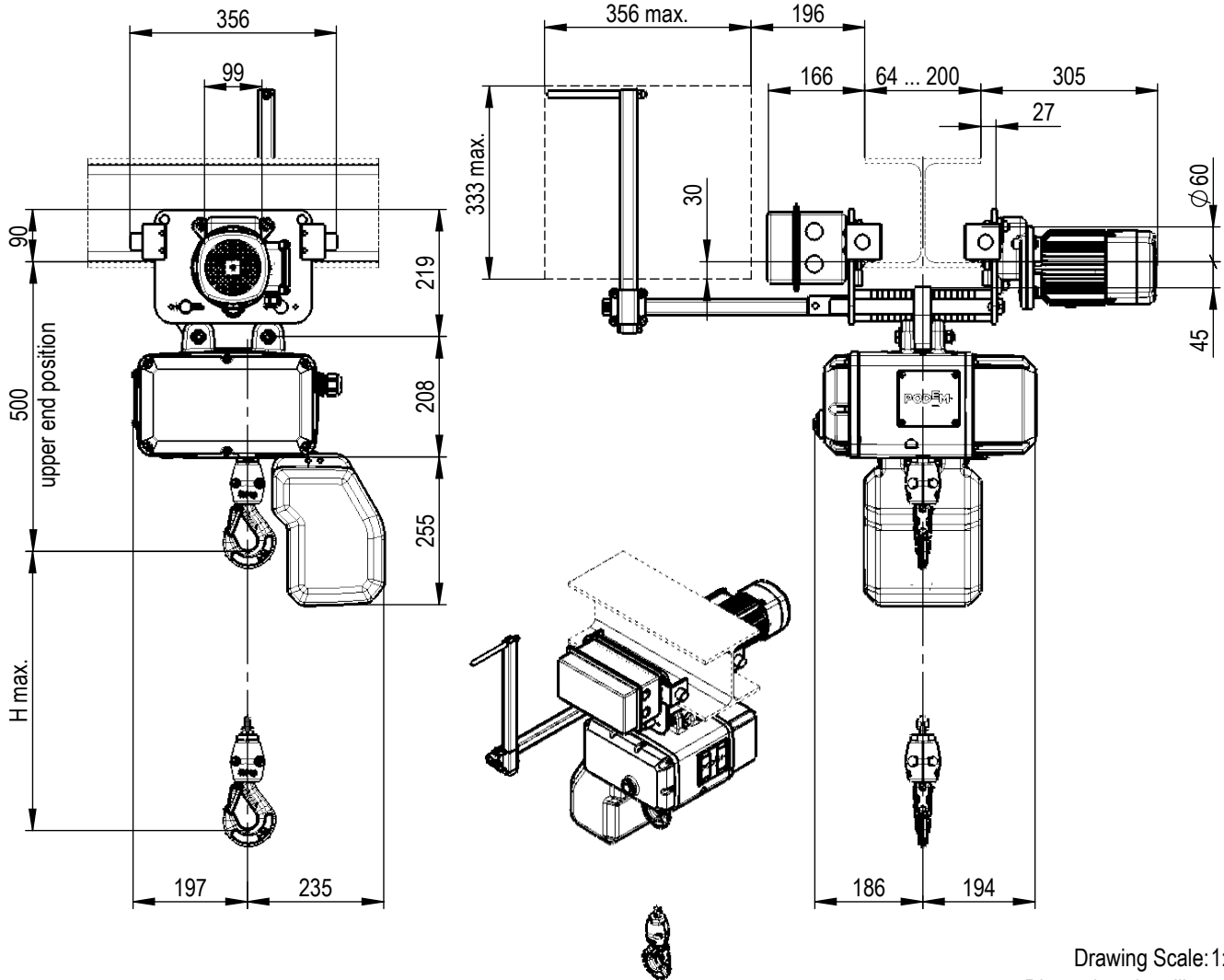

Drawing Scale: 1:12  
Dimensions in millimeters

Date: 24.03.2022

### Dimensions and weights

Chain diameter:	5 mm	Hoist weight*:	56 kg
Pitch:	15 mm	Bottom block weight:	1 kg

### Electric Motors

	Hoist motor:	Travel motor:
Designation:	n.a	DAS 56K - IP55
Voltage:	400 V / 50 Hz; 24 V	400 V / 50 Hz; 24 V
Rated power:	0.75 / 0.18 kW	0.1 / 0.03 kW
Rated current:	n.a	0.54 / 0.49 A
CDF**:	S4, 30 %, 180 C/h	S4, 20 %, 120 C/h

### Reaction Forces

Upper end position of the hook:	R1= 557 kg	Down end position of the hook:	R1= 557 kg
---------------------------------	------------	--------------------------------	------------

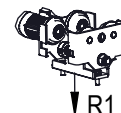

\*Hoist weight includes bottom block; \*\*Service Factor (1/3 Low Speed + 2/3 High Speed).